

BASE ALLOWS FOR MULTIPLE DN150 AND DN225 INLETS TO BE ATTACHED AT ANY ANGLE BETWEEN 45°-315° FROM THE DOWNSTREAM

PLAN

DETAIL 'B'

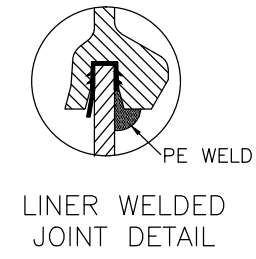

LINER WELDED JOINT DETAIL

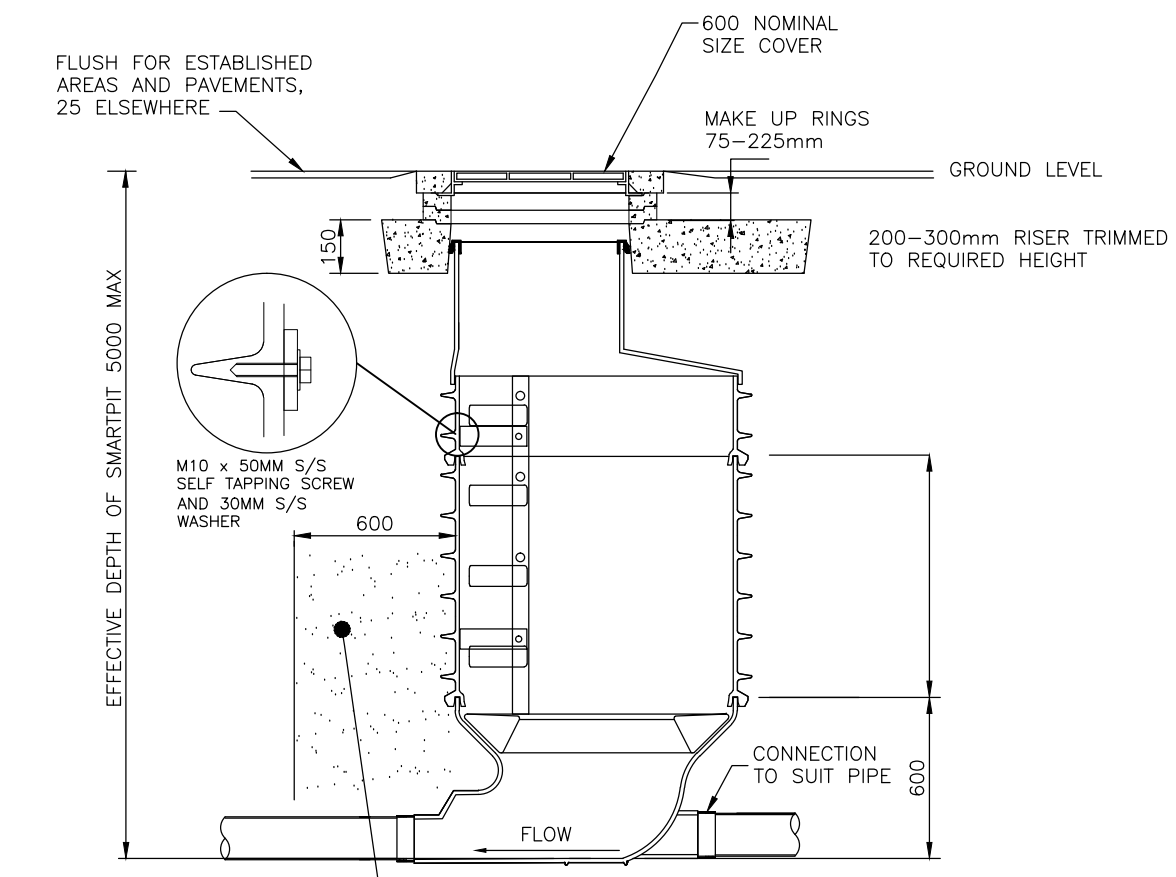

SECTION 'A-A'

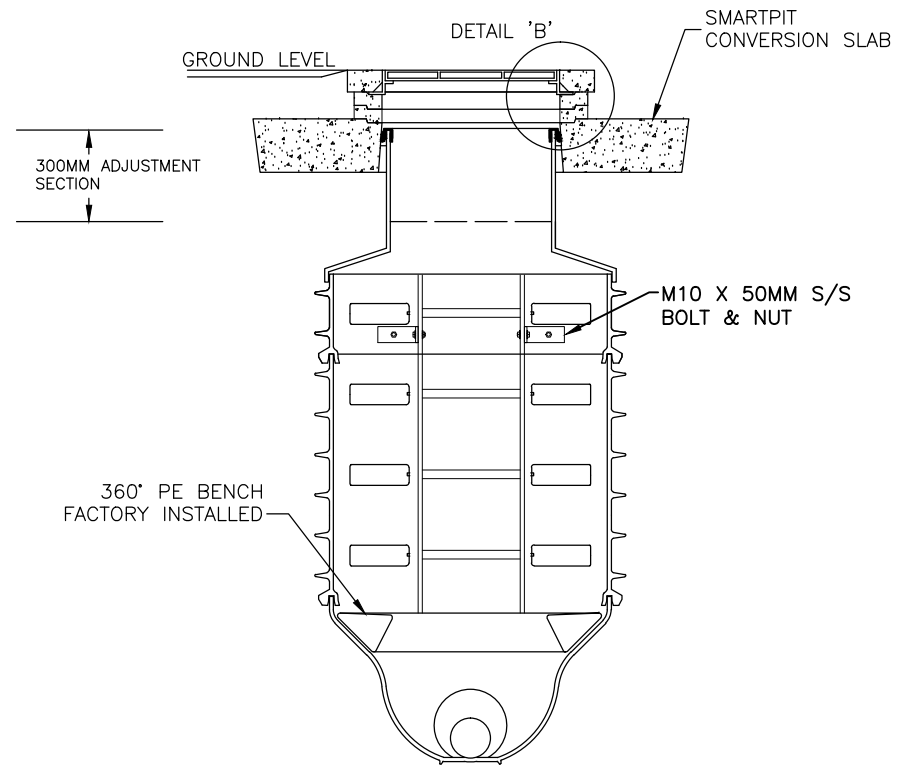

SECTION 'B-B'

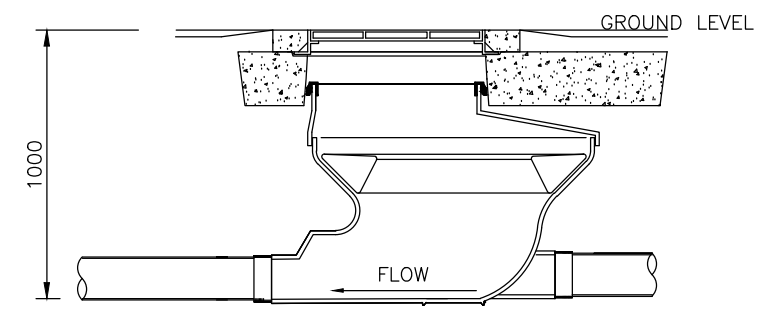

MINIMUM HEIGHT ACHIEVABLE

- GENERAL NOTES
1. ALL DIMENSIONS ARE IN MILLIMETERS U.O.N.
 2. WHERE PRACTICABLE LADDERS SHALL BE CLEAR OF ANY INLETS.
 3. CONCRETE SHALL BE GRADE N25.
 4. CONVERSION SLAB AND ADJUSTMENT SEGMENTS TO BE SUPPLIED BY SAME MANUFACTURER AS LINER SEGMENTS.
 5. CENTRE POINT OF ACCESS CHAMBER TO BE ON INTERSECTION POINT OF SEWERS.
 6. ONLY ACCESS CHAMBERS AND COMPONENTS APPROVED BY LOCAL AUTHORITY SHALL BE USED. THIS DRAWING IS AN EXAMPLE DRAWING. THE DETAILS OF SOME CHAMBERS MAY VARY FROM THOSE SHOW IN THE DRAWING.
 7. PE WELDING TO BE CARRIED OUT BY ACCREDITED PERSONNEL ONLY (REFER TO MANUFACTURER FOR DETAILS).
 8. MANHOLE CAN BE ADJUSTED BY CUTTING CONVERSION TO REQUIRED HEIGHT USING STANDARD CUTTING EQUIPMENT.
 9. BASE, LINERS AND REDUCER COMPONENTS ROTOMOULDED FROM MDPE 15MM WALL THICKNESS.
 10. ACCESS CHAMBERS SHALL BE INSTALLED IN ACCORDANCE WITH MANUFACTURERS INSTRUCTIONS.
 11. BACKFILL AND COMPACTION IN ACCORDANCE WITH LOCAL AUTHORITY INSTRUCTIONS FOR DN150-DN600 GRAVITY SEWERS

BACKFILL AND COMPACTION SEE NOTES. COMPACT MINIMUM 600MM WIDTH AROUND SMARTPIT

B	10/08/15	GENERAL REVISION TO SUIT DRAWING SET	SF	BK
A	05/08/15	ORIGINAL ISSUE	SF	BK

SMARTSTREAM TECHNOLOGY
This drawing is the property of SmartStream Technology and shall not be copied without permission.

DO NOT SCALE FROM DRAWING

 SCALE: DIAGRAMMATIC

DRAWN BY: SF
 CHECKED BY: BK
 DATE: 05/08/15
 DATE: 06/08/15
 ALL DIMENSIONS ARE IN MILLIMETERS

TYPE 1 ACCESS CHAMBER (SMARTPIT) FLAT TOP CONVERSION (WITH STEPS) INSTALLATION
 DRAWING REF: SST-00008-B
 SHEET: 1 OF 1
 ISSUE: B

ORIGINAL SHEET SIZE
A3